

EXCAVATOR CLAMSHELL TELESCOPIC ARM

Telescopic arm with clamshell is installed on the excavator.

The Telescopic arm consist of a fixed body and a telescopic body that can extend and retract. Matched with the clamshell, it could reach a large excavation radius.



Fast



Stable



Efficient



Safe



FEATURES:

1. Use wear-resistant high quality steel Q550, Q690.
2. **Suitable** for special request projects like city urban.
3. **Reliable wire system and mature grounding technology**
4. Engineering according European standard EN16228, assures the machine working stable and safe
5. Core components are imported from famous brands.

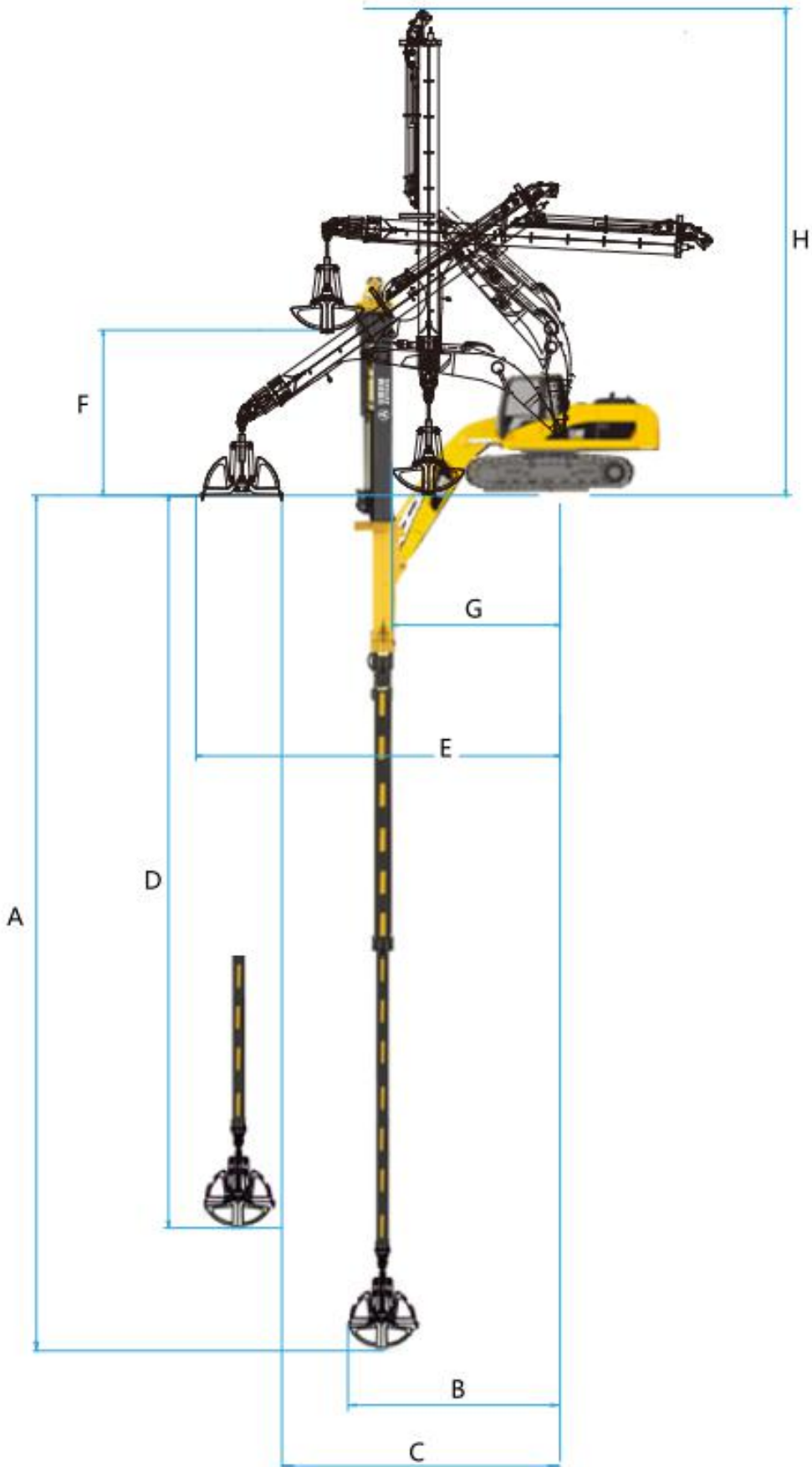
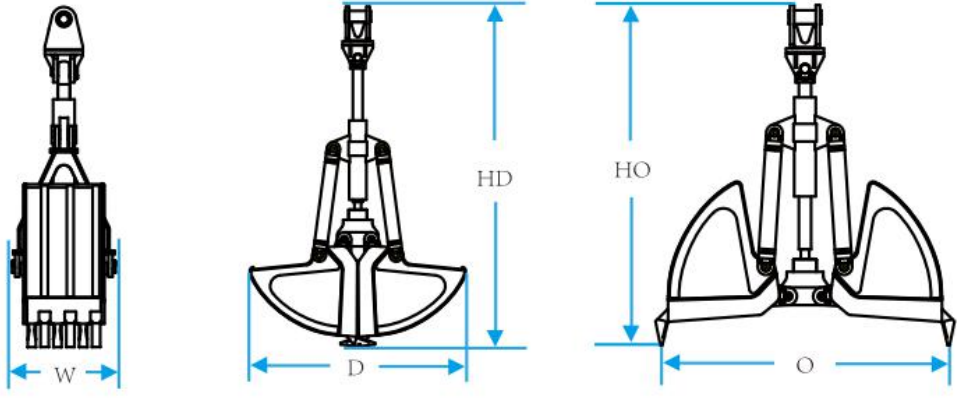

TA系列贝壳式抓斗性能参数
Technical Specifications of TA series Clamshell Bucket

型号 Model	单位 Unit	TA03	TA06	TA12
油缸最大行程 Max. cylinder stroke	mm	380	380	380
油缸最大压力 Max. cylinder pressure	bar	200	200	200
油缸最大压力 Max. cylinder flow	L/min	70	70	70
斗体长度(闭合/张开) Bucket length(close/open)	mm	1600/1790	1955/2210	1995/2210
斗体高度(闭合/张开) Bucket Height(close/open)	mm	2930/2510	3135/2510	3135/2510
斗体宽度 Bucket width	mm	765	765	1200
抓斗容量 Bucket capacity	m ³	0.3	0.6	1.2
抓斗重量 Total weight	ton	0.8	1.1	1.5
适配挖掘机重量 Applicable Excavator	ton	15	23	36

TA系列伸缩臂参数
Technical Specifications of TA series Clamshell Telescopic Arm

最大垂直挖掘深度 Max. vertical digging depth	mm	15200	22490	27180
最大垂直挖掘深度时挖掘半径 Max. vertical digging radius	mm	4670	5845	6400
最大垂直挖掘工作半径 Max. vertical digging radius	mm	6430	7445	8530
挖掘深度(最大垂直挖掘工作半径时) digging depth(reach Max. vertical digging radius)	mm	11825	19920	22370
最大工作半径 Max. working radius	mm	7950	9835	11250
最大卸土高度 Max. unloading height	mm	2870	4465	5770
最小回转半径 Min. turning radius	mm	3980	4485	5460
最小回转半径时整机高度 Height of Min. turning radius	mm	9475	13580	16675
伸缩臂重量 Weight	kg	3600	4600	5600
斗容 bucket capacity	m ³	0.3	0.6	1.2



NOTE!

! Preliminary selection. When making the final selection excavator engine size and hydraulic system design (oil pump arrangement, oil flow rate/pressure etc) as well as site conditions shall be taken into account.

! Specifications are subject to change without notice.